

KAVURMA VE PİŞİRME KAZANLARI

COOKING AND ROASTING MACHINES



KAV-200



KAV-650



Otomatik devirmeli kavurma, pişirme ve kızartma kazanları endüstriyel mutfaklarda ve et işleme tesislerinde yüksek kapasiteli imalat yapan işletmelerde çok amaçlı olarak kullanılmaktadır. Pişirme haznesi otomatik olarak istenen periyotta ve hızda karıştırma yapar. Kumanda paneli üzerinde kontrol edilen kapak ve süzgeç sistemine sahiptir.

Gövde, şase ve buharlı ısıtma kanalları AISI 304 kalite paslanmaz çelikten imal edilmiştir.
Kapılar manuel açılır olarak imal edilmektedir.
Fırın giriş boyutları uluslararası normlara uygundur.
Fırın arabalarının giriş ve çıkışını kolaylaştıran rampalı kanal sistemi.
Fırın içi koruyucu bariyerler.
Kullanışlı ve kolay temizlenebilir.
15 adımdan oluşan 999 program oluşturma imkanı.
CE standartlarına uygun olarak üretilmiştir.

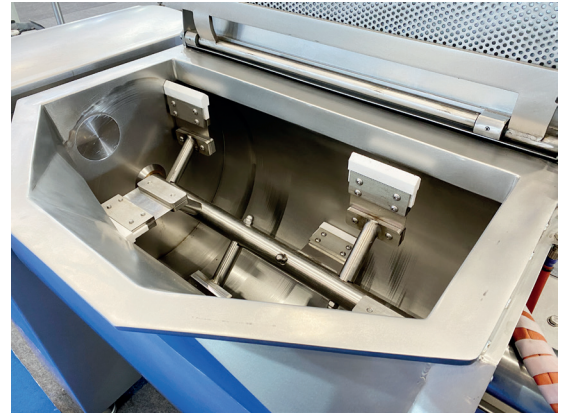

Automatic tilting roasting, cooking and combustion boilers are used for multi-purpose purposes in industrial kitchens and meat processing plants in high-capacity manufacturing processes. The cooking chamber automatically distributes at the desired period and intervals. It has a cover and simple transition system controlled on the control panel.

Body, chassis and steam heating channels are made of AISI 304 quality stainless steel.
Doors are manufactured as manual opening.
Oven inlet sizes conform to international norms.
Ramp channel system that facilitates the entrance and exit of the oven trolleys.
In-furnace protective barriers.
Convenient and easy to clean.
Possibility to create 999 process consisting of 15 steps.
It is produced in accordance with CE standards.

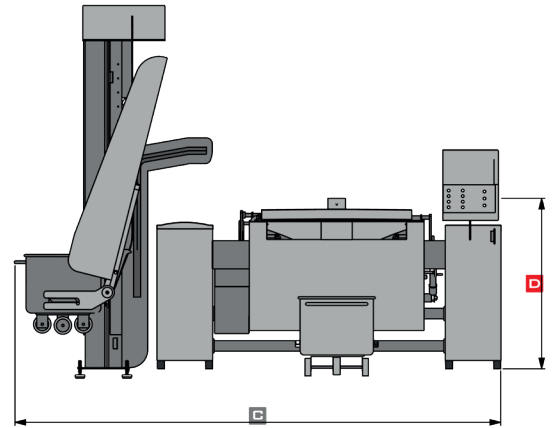
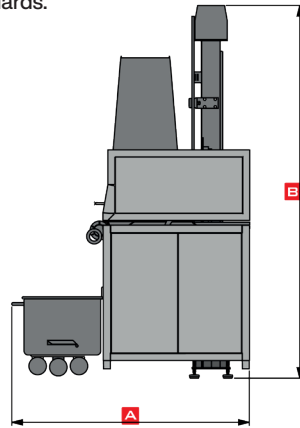

KAV-650

ÖLÇÜLER DIMENSIONS mm	KAV-200	KAV-650
A	1430	2020
B	1600	3170
C	1815	4135
D	1355	1450

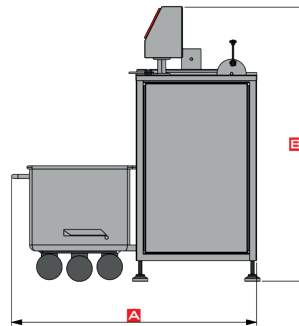

KAV-200

MODEL	KAV-200	KAV-650
Kapasite Capacity	120-160 lt/s lt/h	350-450 lt/s lt/h
Voltaj Voltage	380 V / 50 Hz	380 V / 50 Hz
Güç Power	4 kW	-